

Control of connecting rods

General

The connecting rod is one of the most important element of the motor, that requires a very high manufacturing accuracy. It is also one of the most complex parts, since generally the first operations of a normal working cycle are performed on connecting rod and cap separately, and the next on the two joined pieces which are then separated again to enable the mounting of the big eye to the crankshaft.

For each motor the connecting rods needed are two, four or even six depending on the number of cylinders, therefore it is very important to have accurate and dependable control procedures and stations in production lines.

Connecting rods are one of the few motor pieces which are asymmetric and provided with a very fast alternating motion; therefore it is very important that this part is balanced and that all connecting rods mounted on the same motor have the same geometrical and dynamic characteristics.

Connecting rods are controlled not only from a geometrical point of view but also weight and weight distribution along the connecting rod body are very important and have to be controlled.

The manufacturing operations of connecting rods can be different and depend on the characteristics of each production line; therefore also the control requirements can change and the measuring stations must generally be adapted to each production line.

This booklet describes a selection of typical controls performed by Metrel units. This does not mean that only these can be delivered. Metrel has a wide range of available applications and has the know-how to design and create specific solution for any requirement.

Control type

In addition to the division into automatic and manual units, described later on, the units can be divided according to the purpose of the control operation:

- *inter-operational control (process control)*
- *final control (sorting)*

Inter-operational controls, generally called post-process stations, ensure that each single manufacturing operation is correctly performed and, if a problem arises, correcting actions will be taken immediately avoiding that defective parts proceed to subsequent operations with additional costs and a waste of resources. This control type monitors the production process keeping it under control, and for this reason is also called process control.

The final control has a double purpose : the first is to grant that each finished piece is within the prescribed tolerance limits indicated on the drawing, and the second to sort, when required, the connecting rods in various classes according to weight and, sometimes, also according to the class of big eye and small eye diameter.

The requirements which have to be met by of a connecting rod control station are therefore quite stringent and need sophisticated design both for the mechanical and electronic units.

As production lines for manufacturing connecting rods can be quite different, it is not possible to offer a general solution to all possible control problems. In this booklet we will describe a selection of stations for various process control applications and complete the description with some final control stations for connecting rods.

All control operations can be solved by manual, semiautomatic or fully automatic control stations, according to the production rate and automation requirement of the manufacturing process and line where they have to be installed. Whenever a fully automatic station is required, it will be necessary to receive from the customer a detailed information regarding the transfer line to design the loading and unloading fixtures of the control station according to the production line characteristics.

All electronic units described in this booklet are Comparators, and the controls performed are therefore comparative and not absolute measurements. This means that they will detect the dimensional difference between the part under test and a Master whose know

dimensions are stored in the Unit. All measurements carried out on the connecting rod are *static*, i.e. are performed on the part at rest.

The electronic unit is set to zero at regular intervals performing a “zeroing cycle” on the Master. The deviations of the measurements on the sample with respect to that of the Master will be detected and displayed.

Resolution and repeatability of the unit

Resolution and repeatability are two different concepts. Resolution is the minimum dimensional variation the transducer can pick up and display after a proper electronic amplification. Repeatability indicates the measurement deviations which can be expected repeating the same measurement, in the same conditions, due to measurement uncertainty. From the measuring point, i.e. from the point where the probe is in contact with the piece, till the end signal which appears on the video screen or on a column display, there is a signal transmission chain composed by mechanical and electronic elements with their own inaccuracies that sum up to the station repeatability. Evaluation of repeatability is obtained computing the variance σ of a number of subsequent measurements, generally 25 to 50, performed on a Master part.

Following values apply to on METREL units :

- resolution = 0,05 - 1 micron

- repeatability = better than $\pm 3\sigma \leq 1/5$ of tolerance (on 50 subsequent measurements on master with minimum tolerance of 10 micron).

Even for static measurements, the final value is obtained by the averaging a series of measurements.

1)- Control on the raw piece

In this operation the symmetry of the connecting rod central body is checked with reference to the supporting sides both of big eye and small eye. The information gathered with this control allows to reject abnormally offset or deformed connecting rods, and also to give more data to the operator for the following facing operation.

After facing both sides, the control is repeated in another station with the same placement of transducers.

Tolerance values which sometimes appear in our drawings, always refer to a particular case; each type of connecting rod will have its own tolerances.

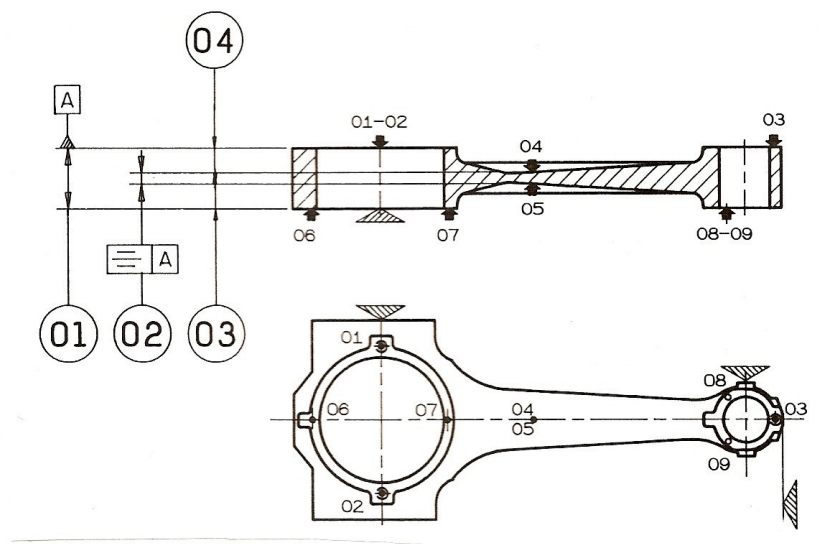

Figure No.1- Control on the raw piece

01 = big eye width measurement

02 = rod centring with reference to big eye plane

03 = plane measurement

04 = other plane measurement

2)- Small eye control

The next operation is cutting the connecting eye and machining the small eye.

The small eye diameter is checked together with its position with respect to connecting rod axis and the orthogonal axis, and the big eye reference plane position, (opposed to junction planes). (figure No.2).



Figura N°2- Small eye control

01= small eye diameter control

02 – 03= perpendicularity control

04 – 05= distance control from references

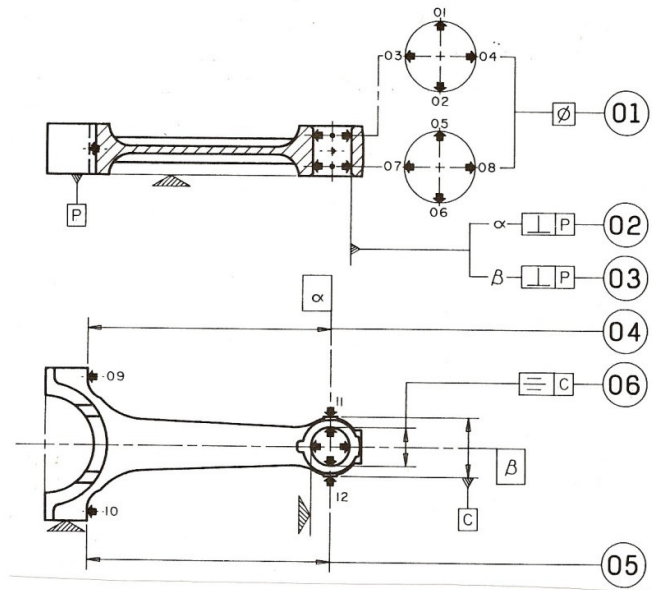
06= distance control from references

3)- Position and dimension control of big eye notches

The notches on the 2 pieces forming the big eye are controlled according to the following layout. (figure No.3).

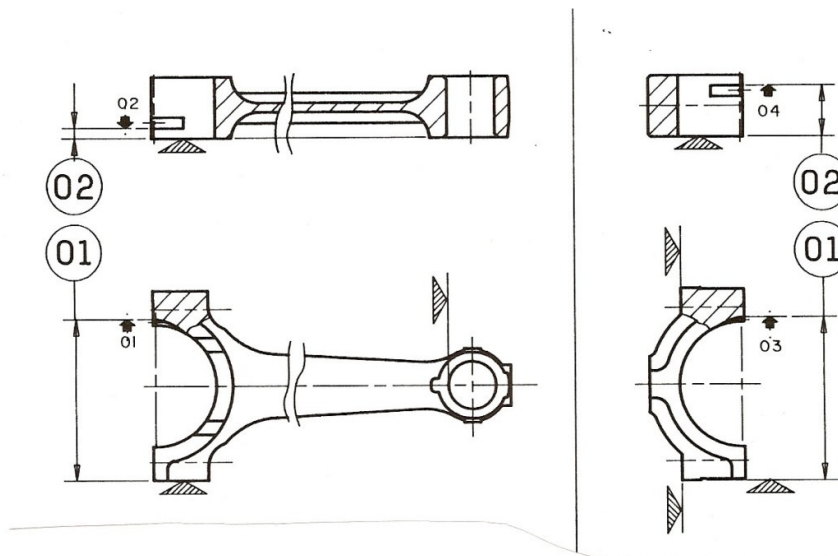

Figure No.3- Position and dimension control of big eye notches

01= notch depth control

02= notch position control with respect to connecting rod face

4)- Hole diameter and position control

This is a very important and difficult control, since in two bores, slightly greater than 8 mm, it is necessary to insert 4 + 4 probes to measure diameter and position with respect to the reference planes.

Measurements and tolerances in the drawing below, refer to a particular case and give an idea of a typical control problem. (figure No.4).

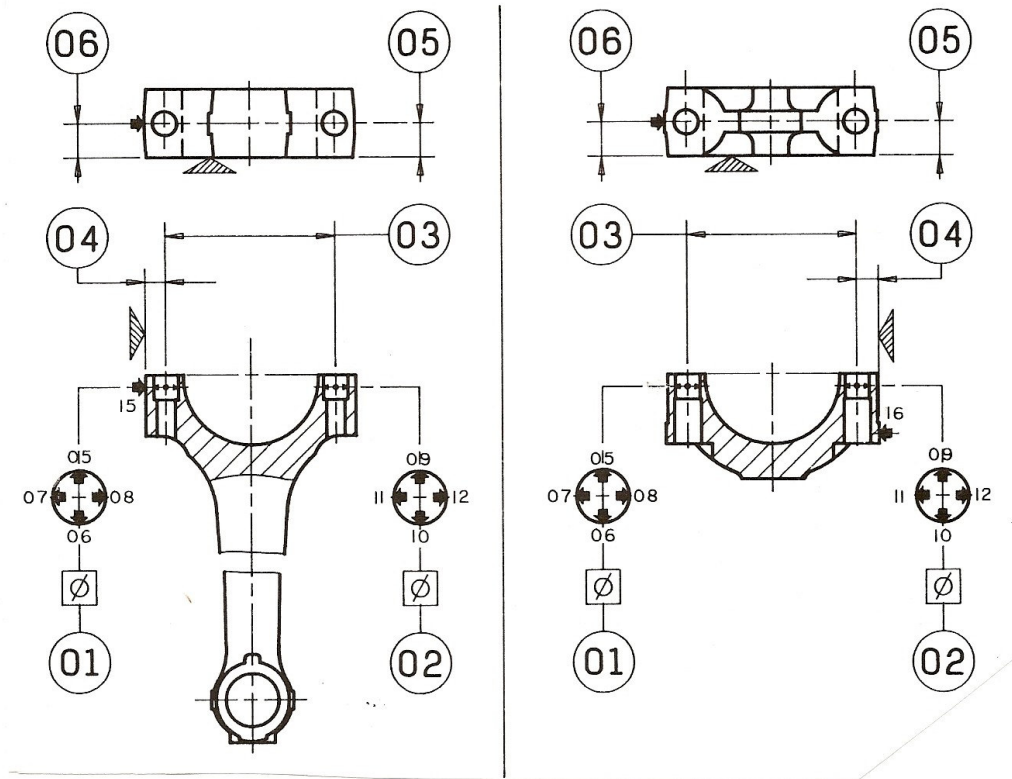

Figure No.4- Hole diameter and position control

01 – 02= hole diameter control (diameter = $8,21 \pm 0,01$)

03= centre distance among holes control (centre distance = $55,6 \pm 0,075$)

04= hole axis distance from plane control (distances $6,65 \pm 0,075$)

05 – 06= hole axis distance from connecting rod face control (distance $11,15 \pm 0,1$)

5)- Final geometrical control

Let us now consider the control of the finished connecting rod. This control is performed in the same way also when the machining cycle is different from the one taken into consideration, i.e. when the connecting rod is *broken* in correspondence of the big eye after finishing.

In this phase not only the big and small eye diameters are controlled, but also their roundness, taper, centre distance, “*bend*” and “*twist*” i.e. the curvature and torsion of the connecting rod.

If sorting in classes and marking according to big eye and/or small eye diameter is required, the unit is equipped with a punch marker or micro-bits marker which prints the class number on the connecting rod body.

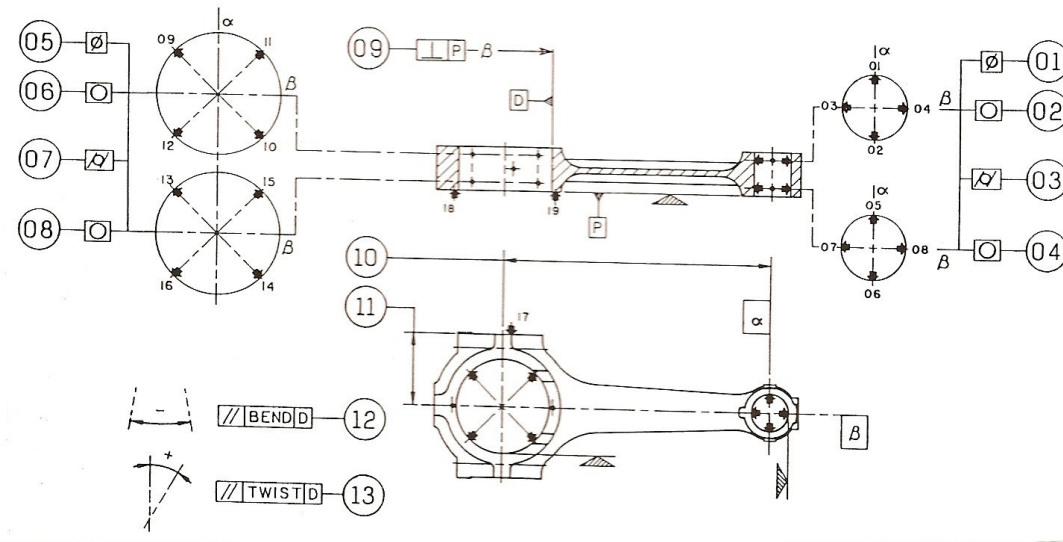

01	small eye diameter	09	plane perpendicularity with reference to big eye
02 - 04	small eye roundness in 2 sections	10	centre distance
03	small eye taper	11	big eye position with respect to reference planes
05	big eye diameter	12	BEND control
06 - 08	big eye roundness in 2 sections	13	TWIST control
07	big eye taper		

Figure No. 5- Final geometrical control

6)- Weight control

When the unit is set to zero with a master with known weight moments, it is possible to check total weight and weight distribution of big eye side and small eye side.

In the application described below, the big eye side weight is divided into 5 classes; and the small eye side in 4. This means that 20 classes of connecting rods according to weight characteristics are possible.

On the motor, connecting rods of the same class must be mounted. Each connecting rod is automatically marked with the class number. The sensitivity of this measurement is 1 gram.

If measurement is performed manually, (i.e. manual loading), to facilitate the operator, the unloading position in the store is signalled by a lit lamp on the shoot where the selected connecting rod is to be placed.

The store has at least 20 shoots, and will be placed near the station.

If weighing and selecting operation are performed on an automatic line, connecting rods are automatically conveyed to the channel corresponding to the corresponding class.

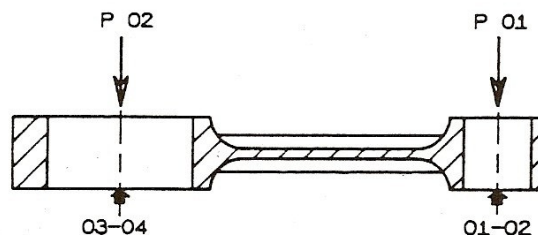

Fig. N°6- Controllo del peso

An automatic machine for final control and selection can be very complex.

The main parts of a typical unit are the following :

- 1) piece conveyor with feeding device of single piece at a time
- 2) pick up station and connecting rod type recognition
- 3) lifting and transferring device for transfer to the next station of the machine
- 4) dimensional control station (small and big eye diameters, centre distance, twist and bend)
- 5) weight and weight class selection control station
- 6) marking station for weight classes and small and big eye diameters
- 7) connecting rod loading device on selection conveyor
- 8) 20 shoots for good pieces, relating to weight classes
- 9) 2 shoots for out-of-weight rejects (1 for over weight and one for under weight pieces)
- 10) 1 shoot for twist or bend rejects
- 11) 1 shoot for dimensional rejects
- 12) 1 shoot for pieces to be re-checked
- 13) optional master loading fixture for automatic zero setting.

Each automatic unit is designed to be mounted in a specific production line, and therefore various options can be customised both according to specific control requirements and line characteristics.

The connecting rod control can be performed in many different ways, corresponding both to machining and production methods. For large productions automatic machines will be chosen, while for limited production rates simple manual stations will be preferred.

Connecting rods measuring station

In case of small series it is possible to use the same control station to check different types of connecting rods. This is possible by replacing only some mechanical parts.

The connecting rod dimensions controlled by this unit are :

- big eye diameter = from 38 up to 56 mm
- small eye " = from 16 up to 32 mm
- centre distance = from 110 up to 220 mm

Operations required for re-equipment for a different connecting rod type are simple and are performed by means of pre-set mechanical parts.

All measuring programmes are stored on the hard disk of S90 electronic unit, which has a capacity of more than 120 Mb, but they can also be stored in an other memory.

Changeover time is around 20 minutes :

The control cycle is very simple and requires the following operations.

- 1) *the connecting rod is positioned on the loading plate over the measuring head*
- 2) *lever rotation : with this operation the loading plate is lowered and the connecting rod is placed in measuring position.*
- 3) *the measuring cycle starts and the result appears on S90 unit. Two lamps, green and red, indicate immediately if the piece is good or not whilst the measurement values appear on the screen.*
- 4) *lever rotation to bring the loading plate back to its initial position.*
- 5) *the controlled connecting rod is unloaded.*

Cycle time is around 10 seconds including loading and unloading.